

HYDROLIFTTM

BORN TO LIFT

CRANE MODEL

1175



SAFETY

Hx

SAFETY

HPS

Inside

SAFETY

HPPro

REMOTE

SAFETY

HPPro⁺

EMS



www.hydrolift.in

FEATURES

- Made from high grade tensile steel
- Indigenously designed
- More suitable for Brick and Block application
- Zinc enriched Polyurethane Paint for all weather conditions and durability
- Available in standard colour RAL3002
- Dual base for more stability and ease of manual outrigger operation

SAFETY

- Cranes with Hx are standard cranes with no additional features
- Cranes with HPS have additional electronic safety features fitted with safe overload protection and hour meter
- Cranes with HPro are installed with radio remote controls for safe remote operations
- Cranes with HPro+ are installed with electronic safety, radio remote control and Intelligent Monitoring System along with Crane diagnostics

DESIGN

- Indigenously design with European Technology complying to EN12999 safety standard for loader cranes
- High Quality and branded products used in the manufacturing of Crane
- Proudly made in India under the Government's 'MAKE IN INDIA' program

HYDRAULIC POWER

- High Pressure Hydraulic Pump
- Operating at 290 bar pressure
- Operating pressure set for optimizing fuel efficiency
- System fitted with overload protection

Load Chart

K1

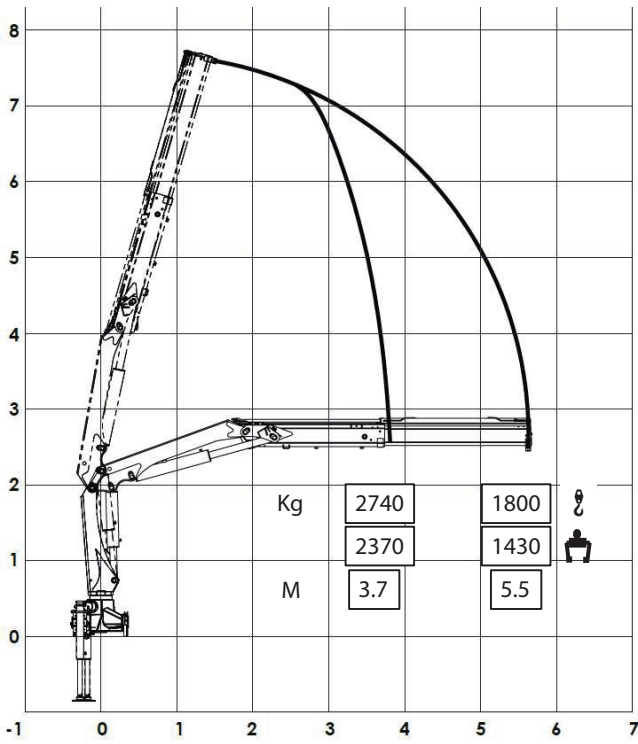

K2

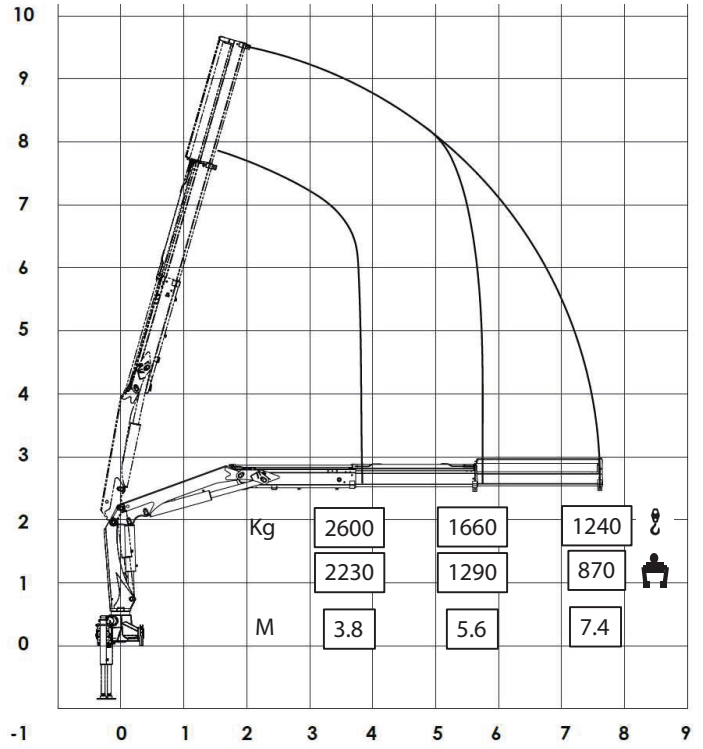

K3

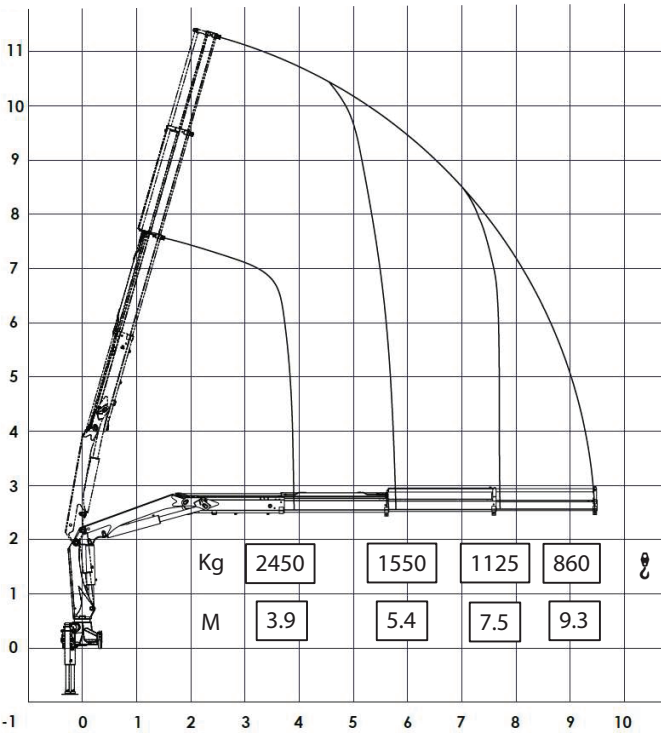

K4

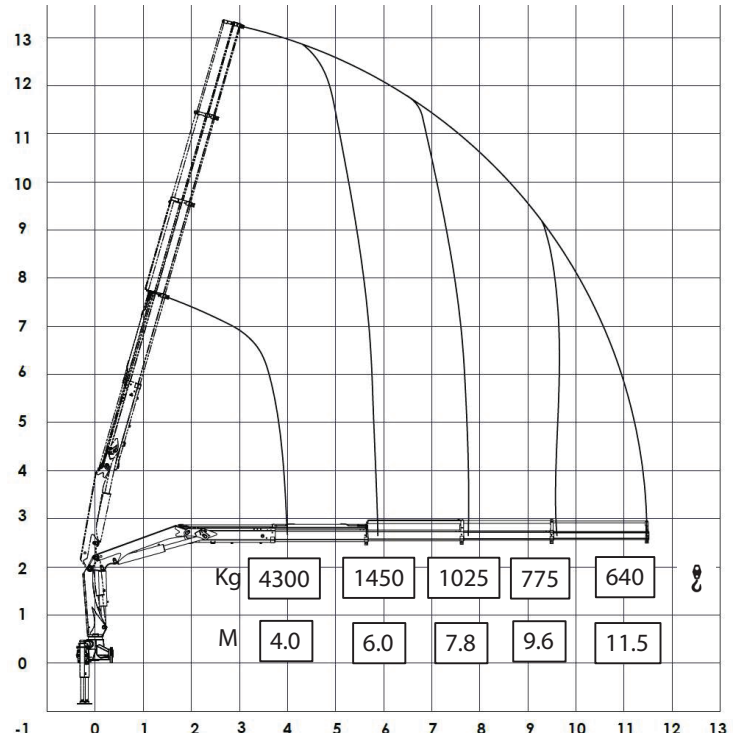

Linear Load Chart

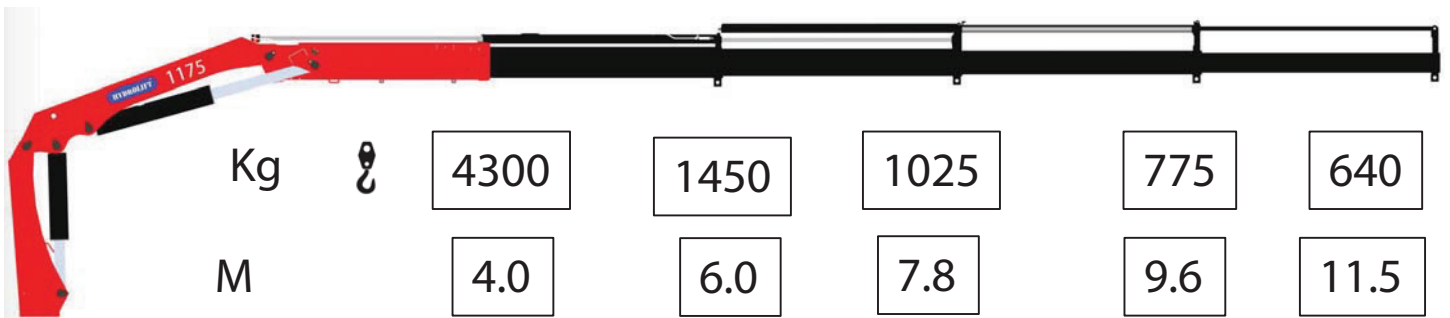
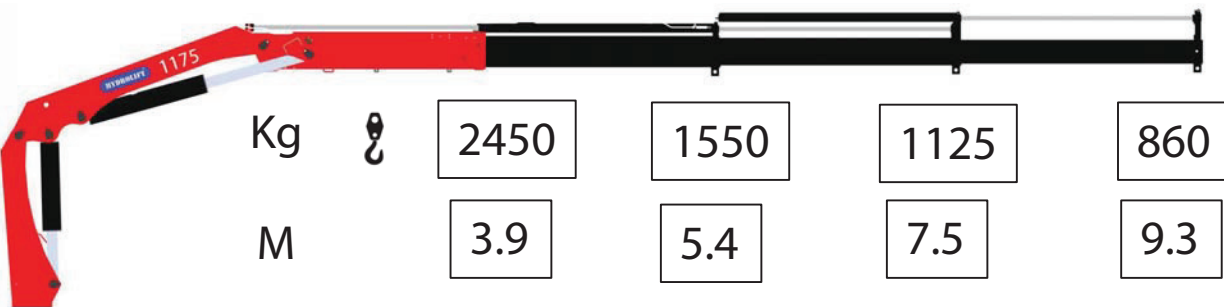
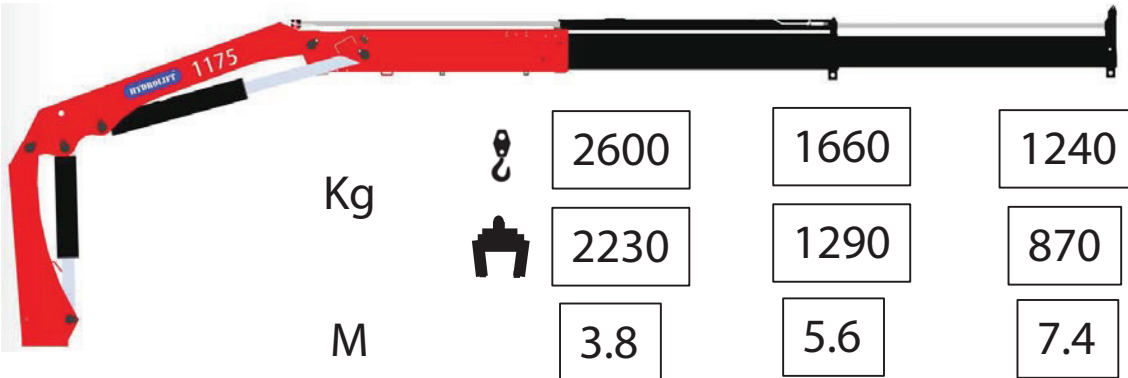
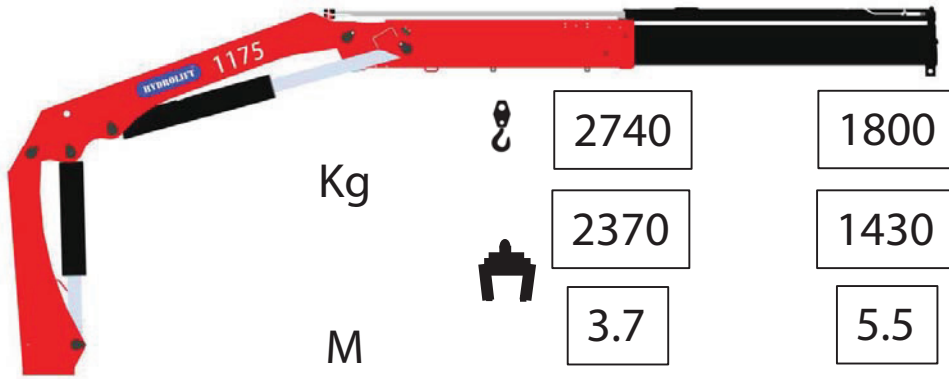

Dimensions

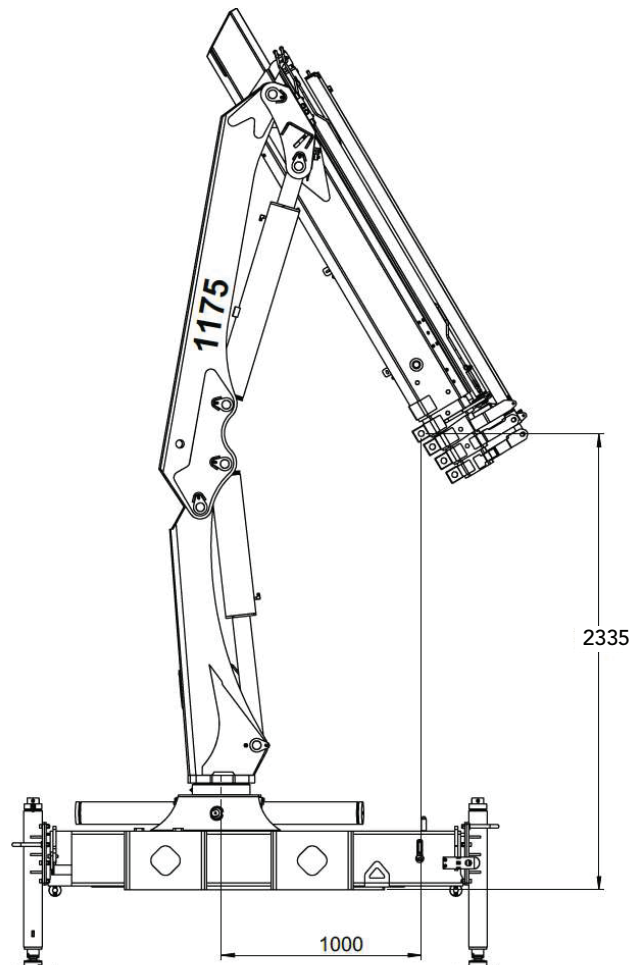
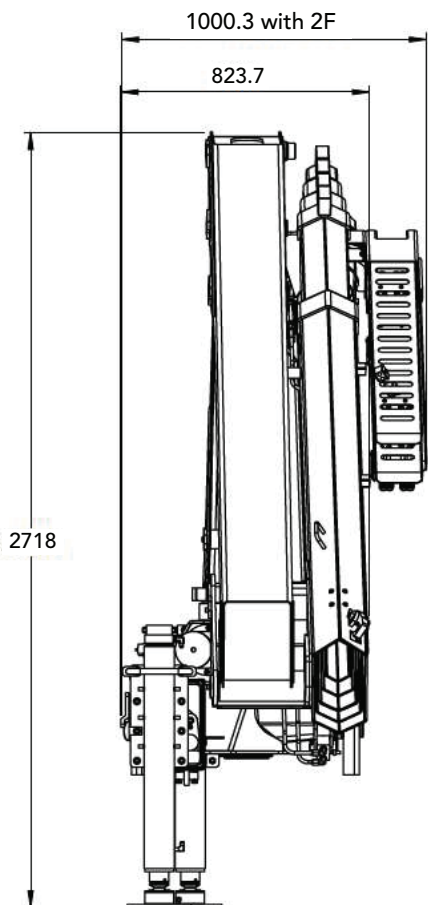
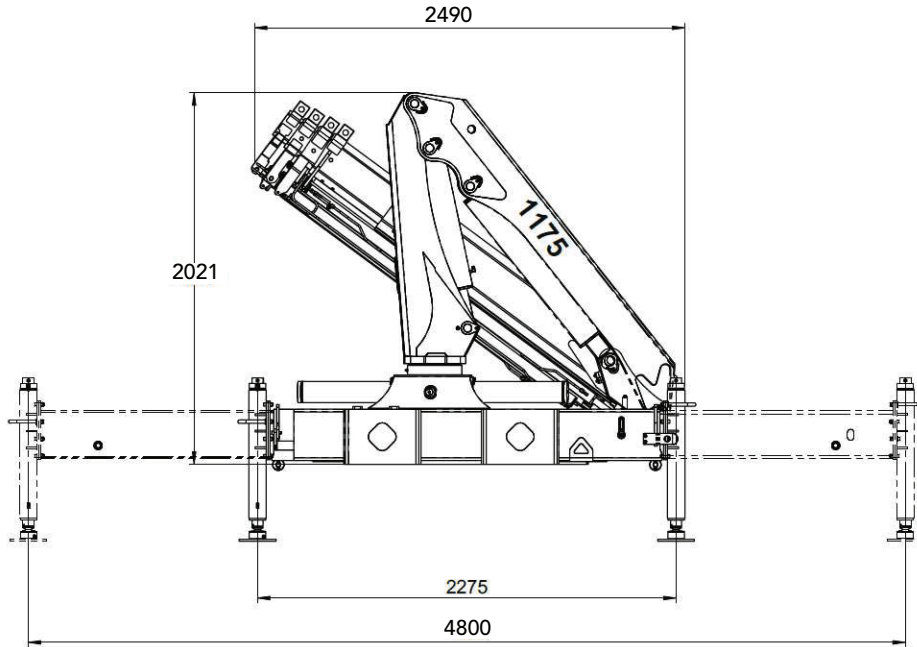

SPECIFICATIONS

Details	UNITS	K1	K2	K3	K4
Load Movement	tm	10.2	9.9	9.6	9.2
Hydraulic Reach	m	5.7	7.6	9.5	11.5
Lifting Capacity	Kg-m	2740 @ 3.7 1800 @ 5.5	2600 @ 3.8 1660 @ 5.6 1240 @ 7.4	2450 @ 3.9 1550 @ 5.4 1125 @ 7.5 860 @ 9.3	2300 @ 4.0 1450 @ 6.0 1025 @ 7.8 775 @ 9.6 640 @ 11.5
Slewing Torque	Kg-m	1280	1280	1280	1280
Stabilizer spread, Standard	mm	3900	3900	3900	3900
Stabilizer spread, Extra long	mm	4800	4800	4800	4800
Height above Chassis when folded	mm	2021	2021	2021	2021
Width when folded	mm	2490	2490	2490	2490
Depth	mm	820	820	820	820
Slewing Angle	Degree (°)	400	400	400	400
Oil Flow	l/min	40	40	40	40
Oil Tank	Ltr	100	100	100	100
Working pressure	bar	290	290	290	290
Standard weight	Kg	1330	1440	1550	1660

HYDROLIFT CRANES PRIVATE LIMITED

Bldg. No. 322/2, Moje Kalote Mokashi, Old Mumbai - Pune Highway, Taluka: Khalapur,
Dist.: Raigad, Maharashtra - 410 206, India | Email: info@hydrolift.in

Dealer