

HYDROLIFT™

BORN TO LIFT

CRANE MODEL
1475

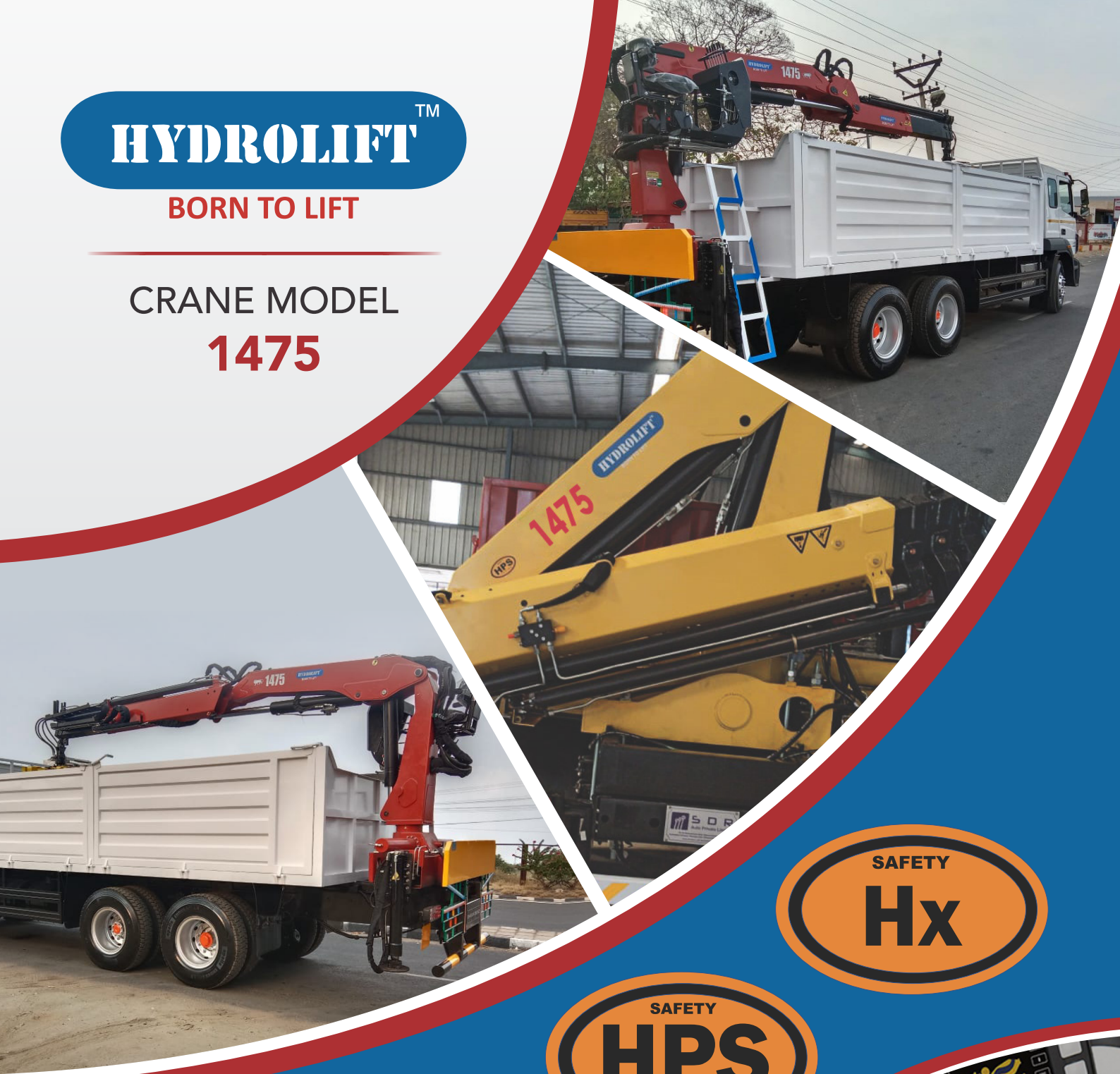

SAFETY

Hx

SAFETY

HPS

Inside

SAFETY

HPro

REMOTE

SAFETY

HPro⁺

EMS

www.hydrolift.in



CRANE 1475

STRUCTURE AND FRAME

- High tensile grade steel
- High-quality steel pins and bushes

WEATHER PROTECTION

- Zinc enriched primer for superior rust prevention
- Superior polyurethane paint
- Standard paint color RAL 3002
- Option - Other colors on customer request

DESIGN FEATURES

- European technology and design, produced in India under Make in India program
- High-quality branded components used in cranes

SAFETY AND CONTROLS

- Cranes with **Hx** are standard cranes with no additional features
- Cranes with **HPS** have additional electronic safety features fitted with safe overload protection
- Cranes with **HPro** are installed with radio remote controls for safe remote operations
- Cranes with **HPro+** are installed with electronic safety, radio remote control and Intelligent Monitoring System along with Crane diagnostics

HYDRAULIC POWER

- High pressure hydraulic pump
- Working Pressure 300 bar

ATTACHMENTS



AUGER



POLYGRAB

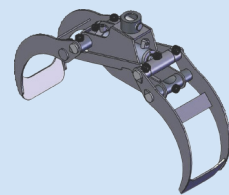

LOG GRAB

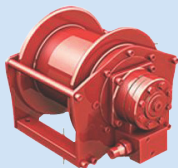

WINCH



MAN BASKET



BRICK BLOCK CLAMP

OPTIONS



RADIO REMOTE



OIL COOLER



EXTRA STABILIZER



TOP SEAT

LOAD CHART

1475 K1

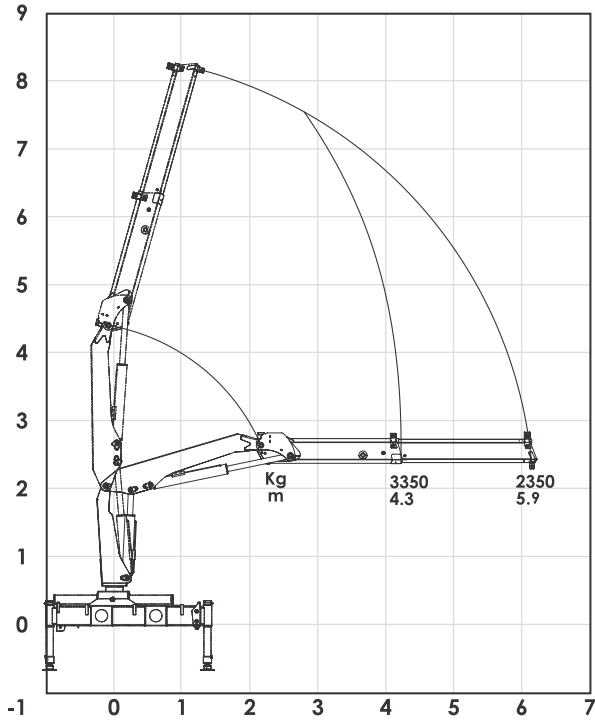

1475 K2

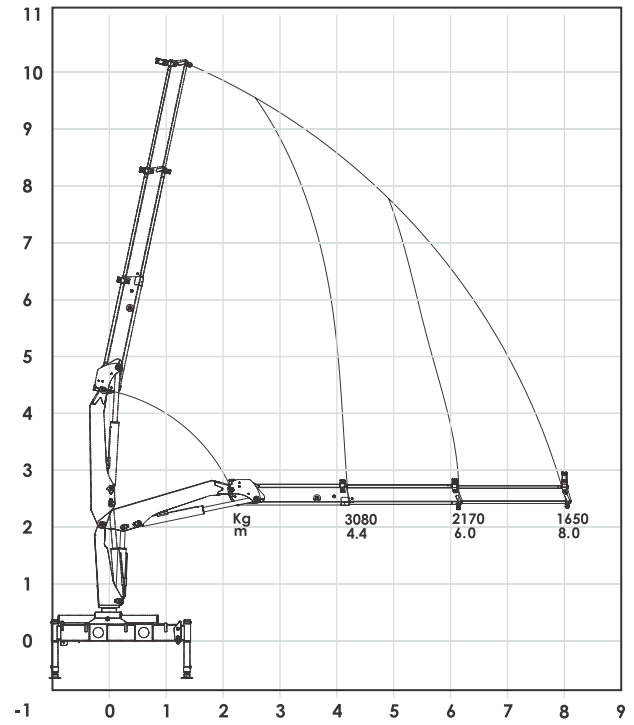

1475 K3

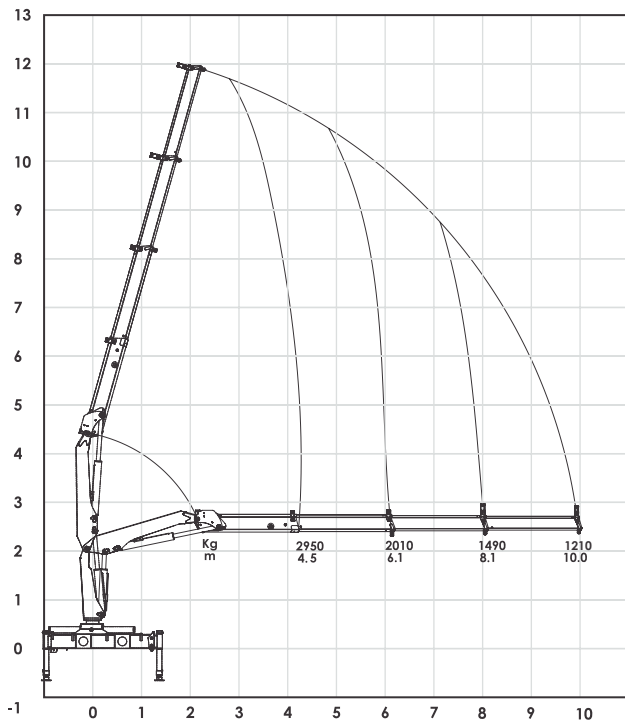

1475 K1

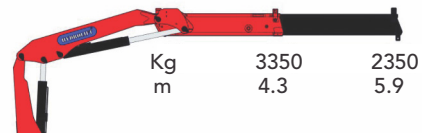

1475 K2

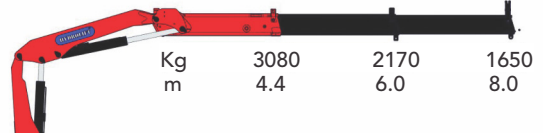

1475 K3

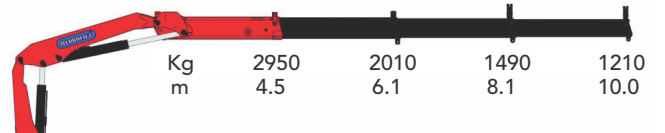

CRANE 1475

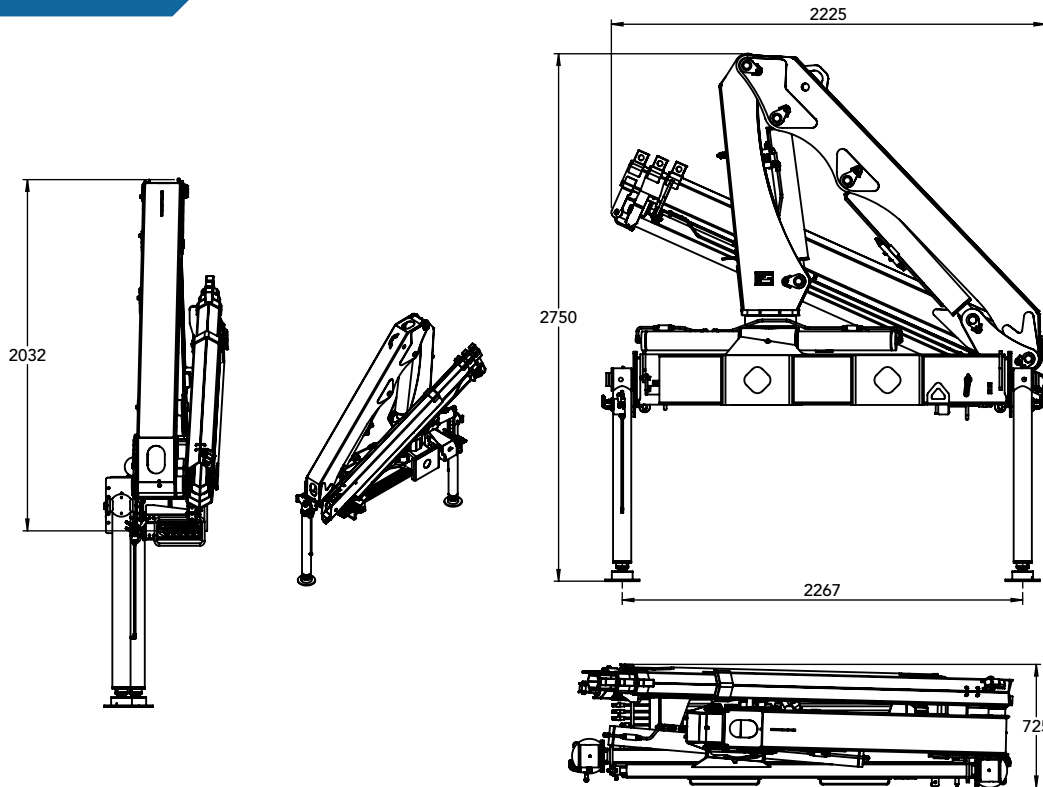

SPECIFICATIONS

EN 12999	UNITS	K1	K2	K3
Load Movement	tm	14.4	13.5	12.9
Hydraulic Reach	m	6.1	8.1	10.0
Load Lifting Capacity	Kg-m	3350 @ 4.3 2350 @ 5.9	3080 @ 4.4 2170 @ 6.0 1650 @ 8.0	2950 @ 4.5 2010 @ 6.1 1490 @ 8.1 1210 @ 10.0
Slewing Angle	Degree (°)	400	400	400
Slewing Torque	Kg-m	1370	1370	1370
Height above Chassis when folded	mm	2130	2130	2130
Width when folded	mm	940	940	940
Length when folded	mm	2550	2550	2550
Stabilizer spread, Standard	mm	5100	5100	5100
Stabilizer spread, Extra long	mm	5500	5500	5500
Standard weight	Kg	1700	1820	1940
Working pressure	bar	300	300	300
Oil Flow	l/min	40	40	40
Oil Tank	Ltr	100	100	100

© Hydrolift Cranes Pvt. Ltd. Specifications and dimensions are subject to change without notice. Please verify before finalization.

HYDROLIFT CRANES PRIVATE LIMITED

Bldg. No. 322/2, Moje Kalote Mokashi, Old Mumbai - Pune Highway, Taluka: Khalapur,
Dist.: Raigad, Maharashtra - 410 206, India | Email: info@hydrolift.in

Dealer