

HYDROLIFT™

BORN TO LIFT

CRANE MODEL
675



SAFETY

Hx

SAFETY

HPS

Inside

SAFETY

HPro

REMOTE

SAFETY

HPro⁺

EMS



www.hydrolift.in

CRANE 675

STRUCTURE AND FRAME

- High tensile grade steel
- High-quality steel pins and bushes

WEATHER PROTECTION

- Zinc enriched primer for superior rust prevention
- Superior polyurethane paint
- Standard color RAL 3002
- Option - Other colors on customer request

DESIGN FEATURES

- European technology and design, produced in India under Make in India program
- High-quality branded components used in cranes

SAFETY AND CONTROLS

- Cranes with **Hx** are standard cranes with no additional features
- Cranes with **HPS** have additional electro-hydraulic safety features fitted with safe overload protection
- Cranes with **HPro** are installed with radio remote controls for safe remote operations
- Cranes with **HPro+** are installed with electro-hydraulic safety, radio remote control and Intelligent Monitoring System along with Crane diagnostics

HYDRAULIC POWER

- High pressure hydraulic pump
- Working pressure 240 bar

ATTACHMENTS



AUGER



POLYGRAB

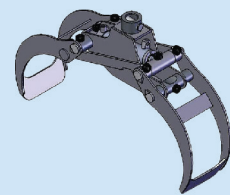

LOG GRAB



WINCH



MAN BASKET

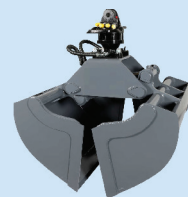

SAND BUCKET

OPTIONS



RADIO REMOTE

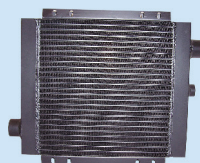

OIL COOLER



EXTRA STABILIZER

LOAD CHART

675 K1

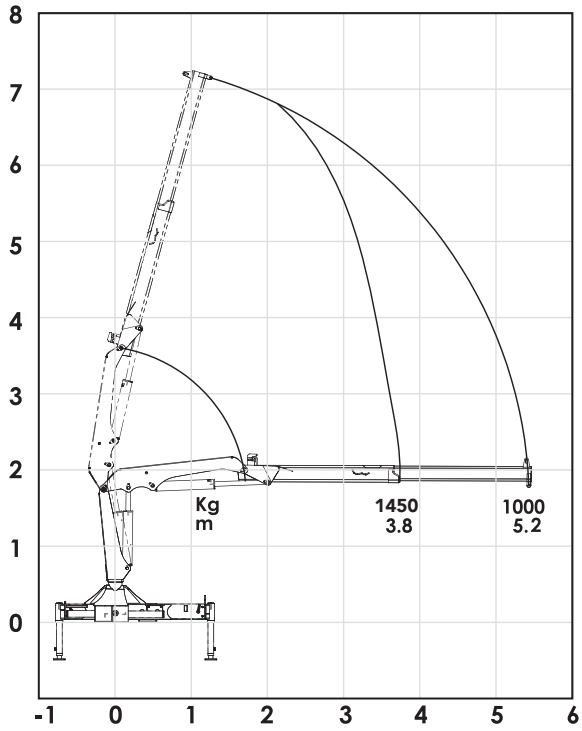

675 K2

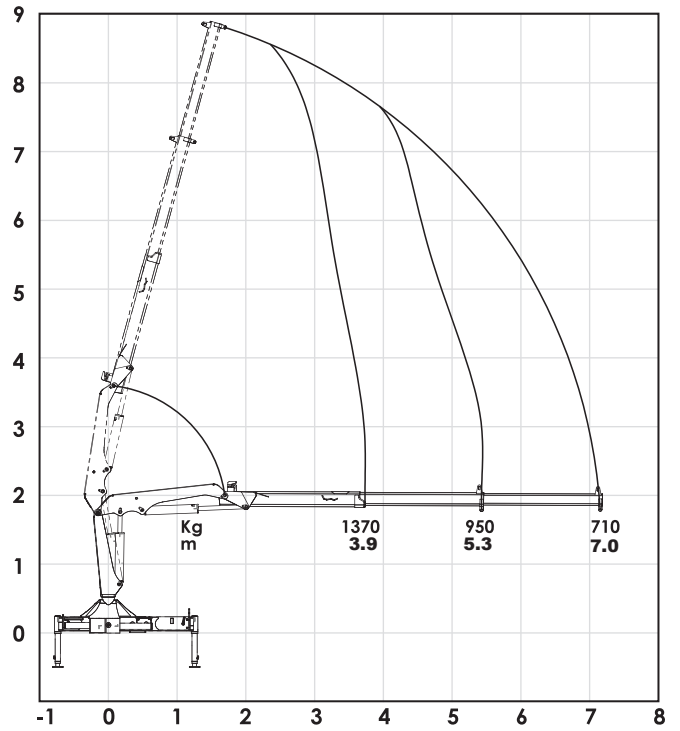

675 K3

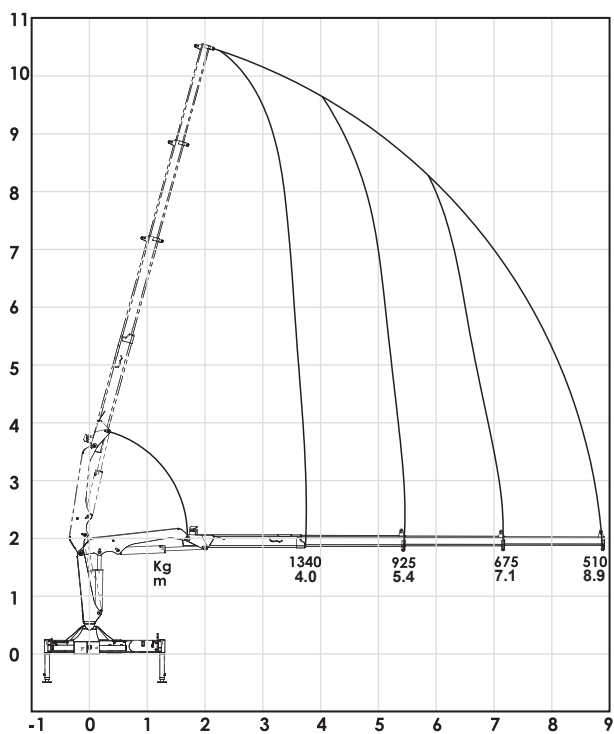

675 - K1

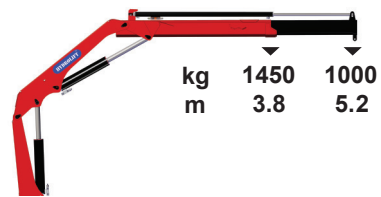

675 - K2

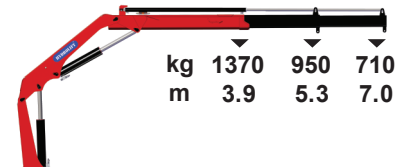

675 - K3

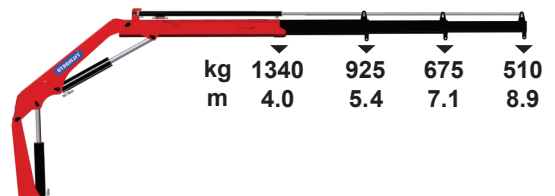

CRANE 675

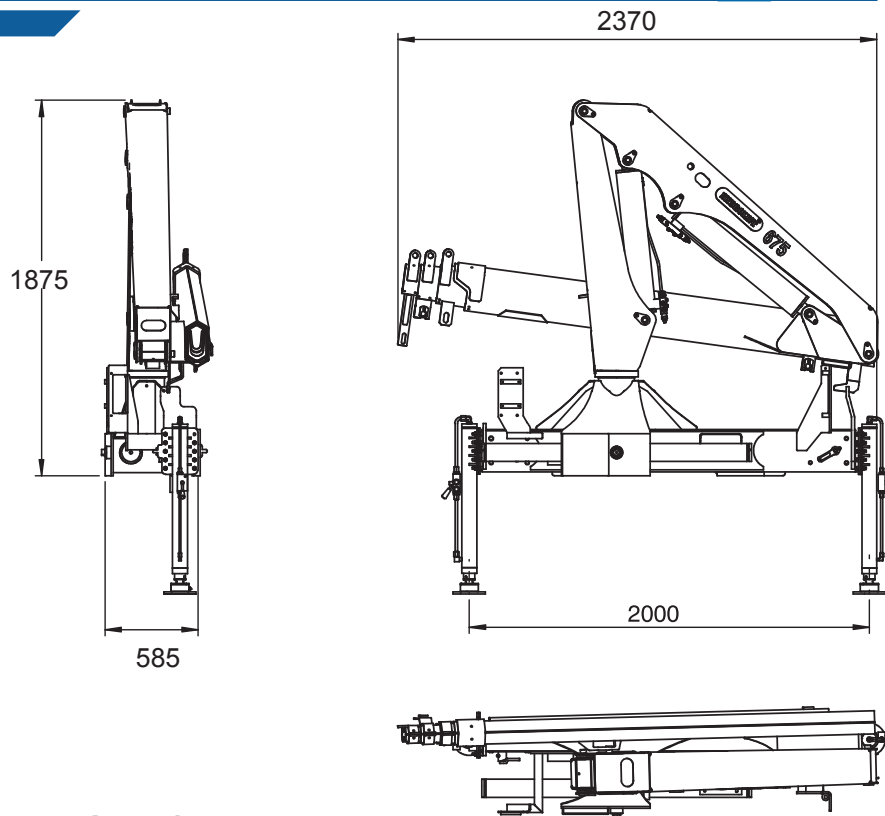

SPECIFICATIONS

EN 12999	UNITS	K1	K2	K3
Load Movement	tm	5.5	5.3	5.1
Hydraulic Reach	m	5.5	7.2	8.9
Load Lifting Capacity	Kg-m	1450 @ 3.8 1000 @ 5.2	1370 @ 3.9 950 @ 5.3 710 @ 7.0	1340 @ 4.0 925 @ 5.4 675 @ 7.1 510 @ 8.9
Slewing Angle	Degree (°)	400	400	400
Slewing Torque	Kg-m	581	581	581
Height above Chassis when folded	mm	1875	1875	1875
Width when folded	mm	585	585	585
Length when folded	mm	2200	2310	2370
Stabilizer spread, Standard	mm	3130	3130	3130
Stabilizer spread, Extra long	mm	4000	4000	4000
Standard weight	Kg	690	760	830
Working pressure	bar	240	240	240
Oil Flow	l/min	25	25	25
Oil Tank	Ltr	35	35	35

© Hydrolift Cranes Pvt. Ltd. Specifications and dimensions are subject to change without notice. Please verify before finalization.

HYDROLIFT CRANES PRIVATE LIMITED

Bldg. No. 322/2, Moje Kalote Mokashi, Old Mumbai - Pune Highway, Taluka: Khalapur,
Dist.: Raigad, Maharashtra - 410 206, India | Email: info@hydrolift.in

Dealer